

UNINTERRUPTIBLE POWER SUPPLY

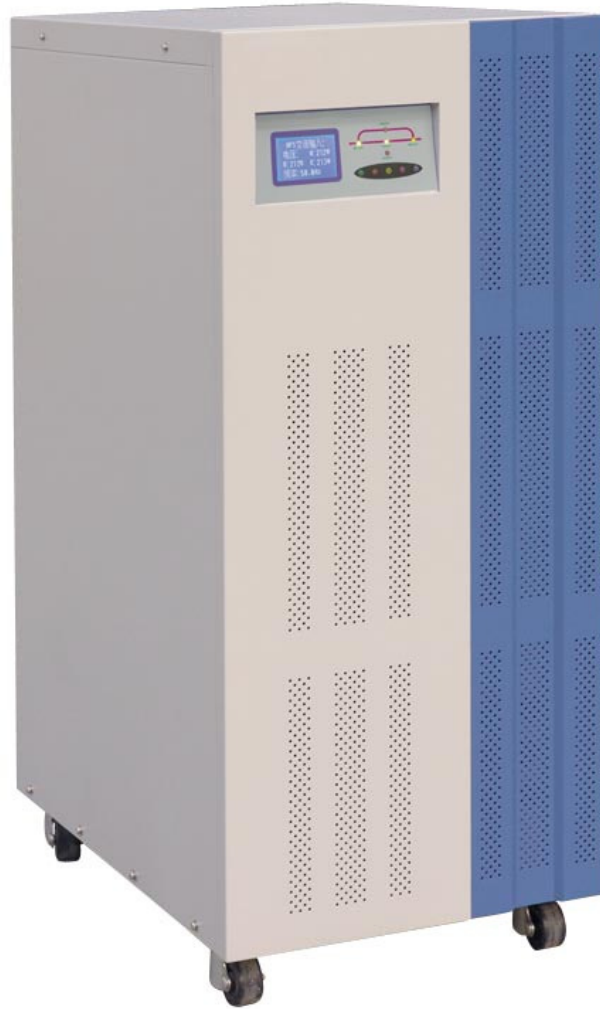

DS-10 to 80KVA USER'S MANUAL

Content

1.Products introduction -----	1
2.Operation demand -----	1
3.Notices -----	1
4.Working principle -----	2
5.Front panel -----	7
6.Installation -----	8
7. Specification -----	11
8. Alarming -----	14
9.UPS start up process -----	15
10.UPS maintenance shutdown process-----	16
11. Urgency shutdown process-----	16
12.Front panel introduction-----	16

1 □ Products introduction

DS (three phase in and one phase out) series UPS is large power and true on-line UPS with range from 10KVA to 80KVA, which adopts advanced digital design, high speed 16-bit chip, ASIC, DDC and large power IGBT&SCR, and shows large capacity, high stability and super performance compared with usual models on the market. All the products have integrated the latest hardware and powerful software in itself, which could provide optimum pure power to integrated server center. This system supports several units connected in parallel through unique control technology.

2□Operation demand□

- Please read carefully the user manual before using machine.
- This manual must be understood and conserved by professional.□
- This manual does not introduce the detail specification.
- This manual just suit to DS (three phase in and one phase out) series UPS.

3□Notices □

3.1 Make sure relevant power input/output/battery/cable.

3.2.it must be steady grounding system.

3.3. There are a lot of high-voltage energy storage device in Machine, please don't open case and check, otherwise cause danger to lift, accept the consequences by oneself. The operator must understand the electrician basic knowledge and pore over the operation instructions.

3.4. Without permission, can't dismantle various kinds of connection cables without authorization.

3.5. Because this product is greater in volume, weight is relatively heavy, can't move

at will, must not split and shake strongly Move, and keep ventilating it well.

3.6. In case of electrification, can't go to discharge the dust; Handy wet towel go to wipe and get rid of the dirt.

3.7. The battery must be changed by the professional and technical personnel, the battery changed out must deliver special circulation and give a new lease of life to the organization to deal with . The battery is " poisonous waste material "

3.8. UPS is not used when being installed a long time, the battery disposed will discharge automatically, at the same time the automatic consumption that chemical energy of the battery, at 25 degrees Centigrade according to the environmental climate around,, the battery must be charged in every three months, if the temperature is greater than 30 degrees Centigrade, the battery should be charged once every two months . Only need to start UPS while charging, and run at least for 24 hours under the normal work pattern.

4□working principle □

4.1. DS 3/1 series UPS adopts advanced digital design, □improved MTBF and steadily □ one lone main control panel control all system. Which adopts microprocessor control and ensure that machine can work steadily and reliably.

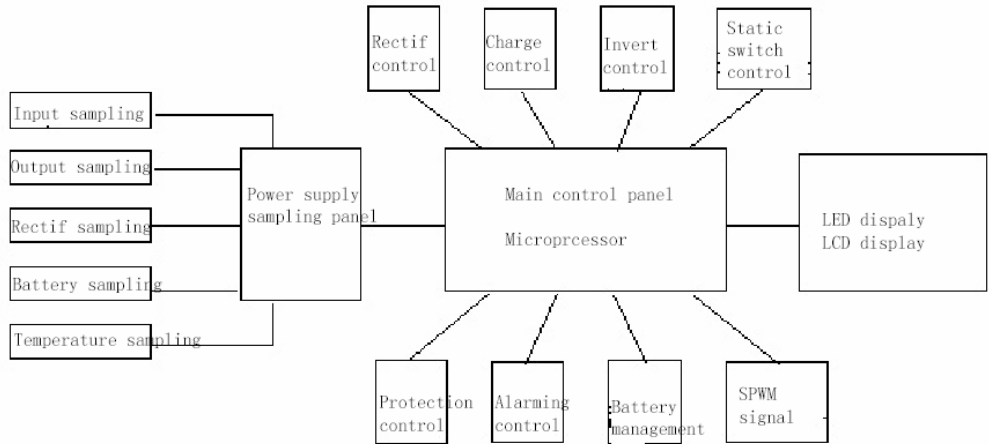

Besides, UPS others parts: invert transformer, input inductance, IGBT, silicon controlled and switch.

4.2. Standard UPS principle □

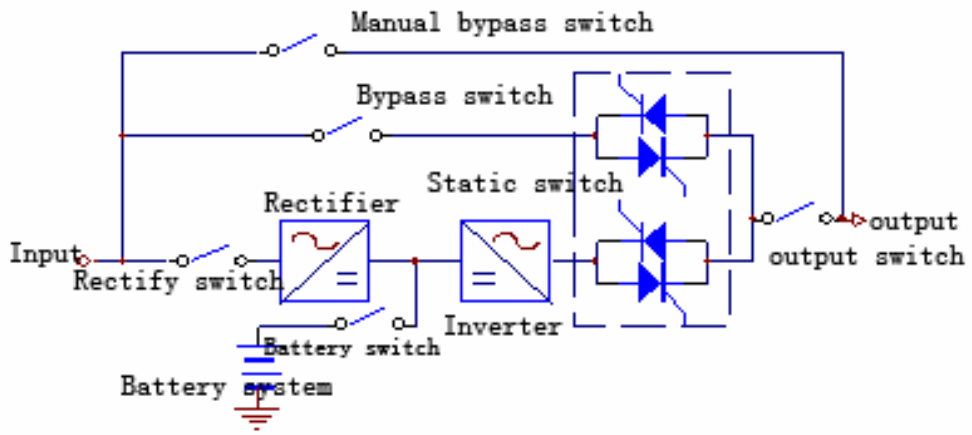

4.3. Mains inverter principle □

After AC input turn to DC filter through rectifier, then inverter invert through SPWM and output AC.

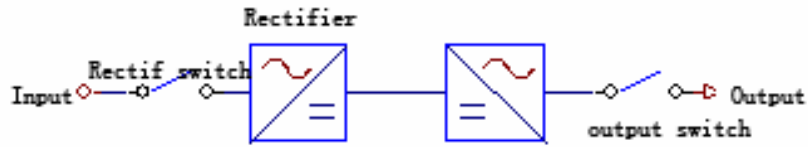

4.3.1. Normal inverter model □

Battery have been recharge full, after AC rectifier, then inverter output.

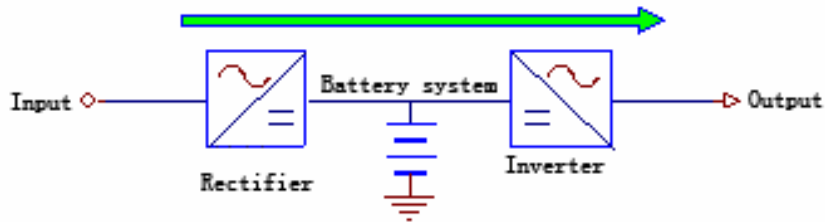

4.3.2. Inverter normally, and battery recharge working model □

battery voltage is low, after AC inverter, on one hand it will charge, on the other inverter output.

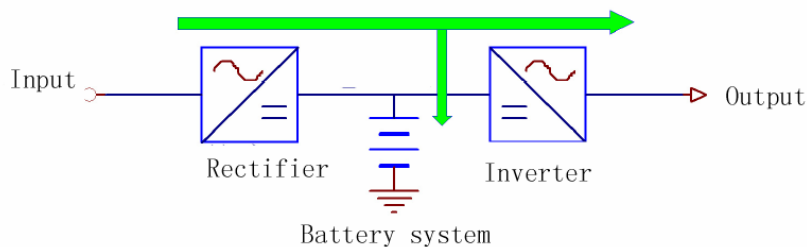

4.3.3. AC input failure, battery-working model:

AC input is failure, battery inverter and supply power.

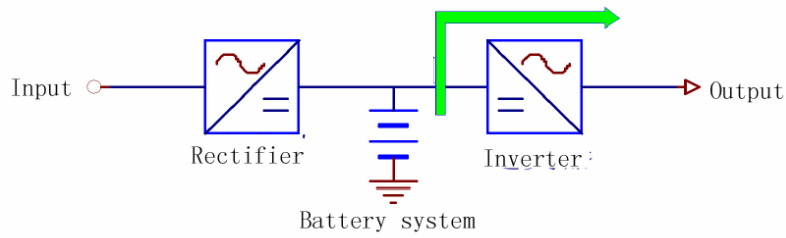

4.3.4. Bypass output working model:

There is AC input, but inverter has been closed, meantime, output is supplied bypass.

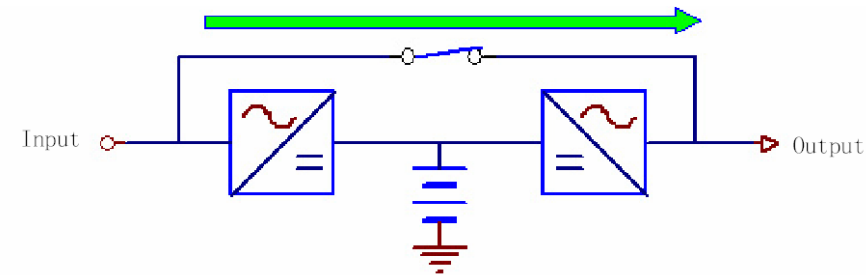

4.4. Function module

4.4.1. Rectifier

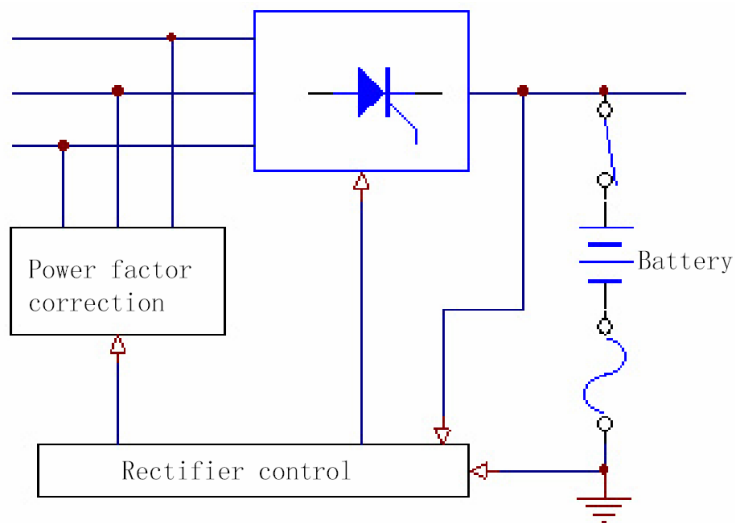

- Protection short circuit rectifier switch
- Lightning arrester
- 6/12 Plus rectifier
- Input inductance
- Battery temperature compensate

-
- Battery floating charging
 - Battery timing balanced charging.
 - The input of rectifier can be limited in rated numerical value, at the same time , battery recharge in constant current, constant voltage, expert engineer can change rectifier working through setting parameter.

4.4.2. Inverter

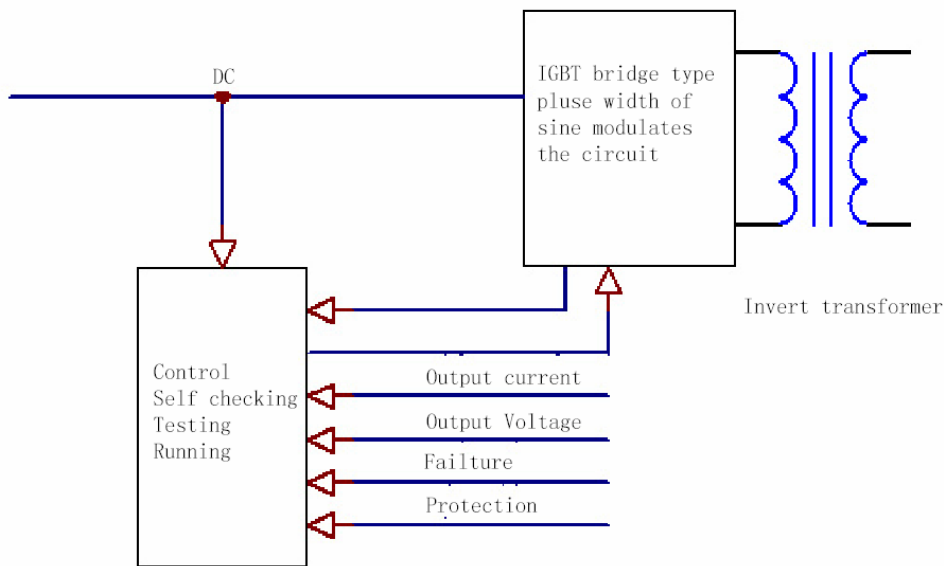

- Inverter output isolation transformer.
- 3 Phase PWM inverter bridge.
- Current sampling
- Voltage sampling
- Feedback control
- Self-testing
- Hardware sense
- Protection circuit

5 Front panel introduction

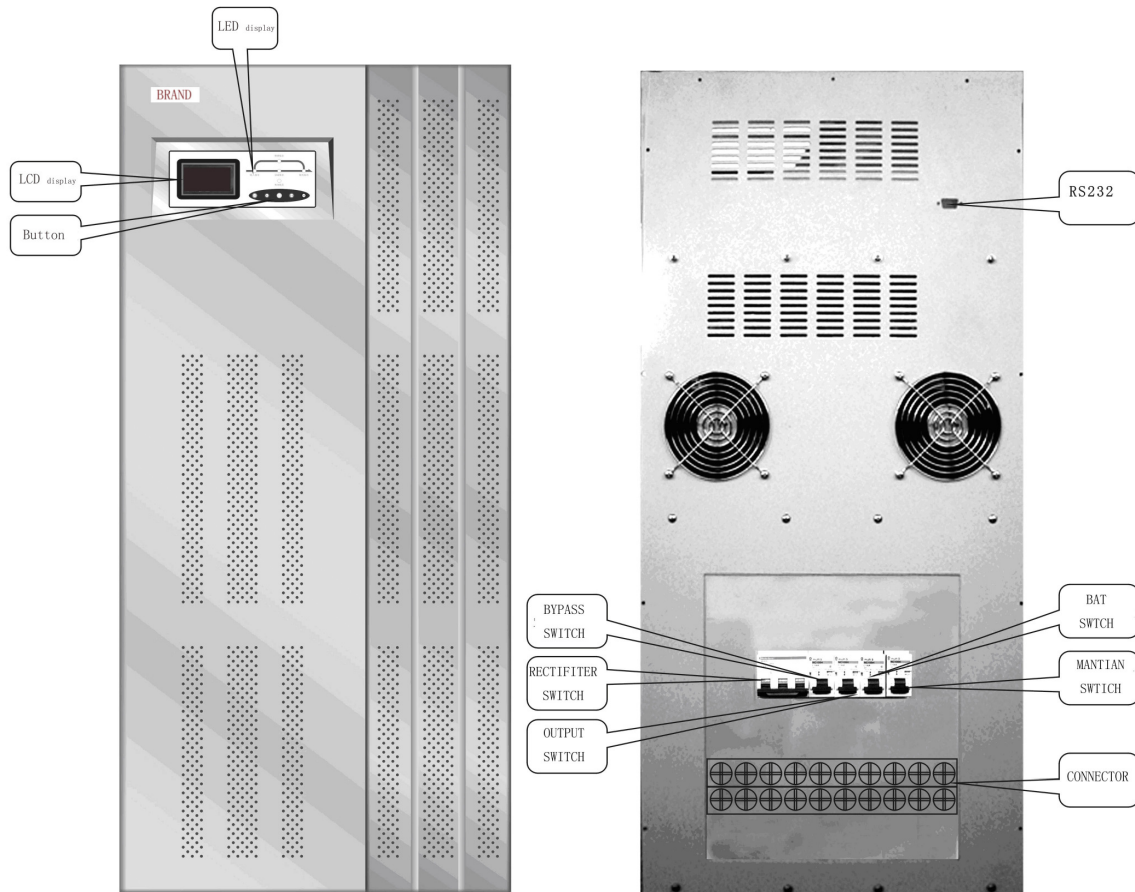

- LED status display-----it indicates working status
- LCD display-----it indicates Various kinds of data
- Fuse pedestal -----it is used by power supply, sampling, fan and so on .
- Input rectifier switch -----Control rectifier input
- Bypass switch -----Control bypass input.
- Output switch -----Control output
- Battery switch -----Control battery input
- Maintenance bypass switch -----Control AC bypass (just use it when maintenance)
- Line bank-----Connect input, output, battery and grounding.

6 □ INSTALLATION:

6.1. Installation environment □

- Temperature □ 0 □ ~ +40 □
- Relative humidity □ 30% ~ 90%
- Altitude □ ≤ 1000M
- Installation environment dimension □ L × W × H □

1500 × 1000 × 2000

- Board pressure □ 2000KG/M²

The indoor environment demanded is as following:

- No dust
- Appropriate indoor temperature: please operate UPS in 0~40 □,

But it is 0 □ when start, the idea operation temperature is 25 □.

- There should be a good heat dissipation system, the following is a feasible method:

A: Natural ventilating system: Only suitable for low heat and vast space.

B: man - made ventilating systems: Need to install the air conditioner when exceeds the peripheral temperature (TE) in chassis temperature (TA). As the TE and TA is close, the capacity of the heat distribution system will increase.

6.2. Check before installation □

Unpack the equipment and inspect again to determine if any external or internal damage has occurred.

Opening the main entrance, meantime, please check if all switches are

disconnection.

6.3. Installation site □

- Please place the UPS in the place where keeps good ventilation, rear panel of UPS and two side faces should keep more than 80cm away from the wall.
- Do not lay goods on the UPS.
- It must have enough room to Overhaul in the front of equipment and above.
- Battery box of equipment must keep enough position on right-hand side for battery overhaul.
- Power line must be connected from bottom of machine.

6.4. Terminal connection diagram:

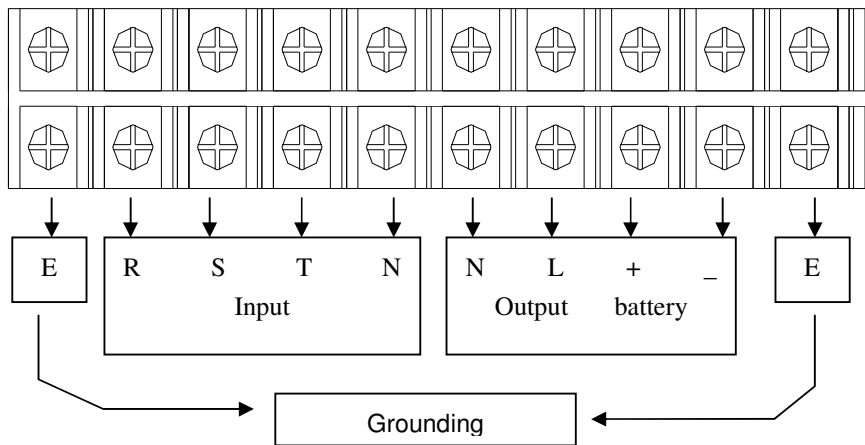

Before UPS is not being installed, please disconnect all switches.

Left: R □ S □ T □ N connect three phase input phase line and median line ;

Right :N □ L connect one phase output phase line and median line;

E connect earth line □ + □ - connect battery positive pole and negative pole.

6.5.UPS three output system 10-80KVA cable specification: (unit: mm²)

Capacity	Input					Output		Battery	
	R	S	T	N	E	T	N	+	-
10KVA	6	6	6	6	6	12	12	10	10
20KVA	10	10	10	10	10	20	20	16	16
30KVA	16	16	16	16	16	35	35	25	25
40KVA	25	25	25	25	16	50	50	35	35
60KVA	35	35	35	35	16	75	75	50	50
80KVA	40	40	40	40	16	100	100	75	75

6.6□ Battery connection

- Opening battery pack.
- Installation battery on the corresponding position and connecting the good battery connecting wire

6.7.connection inspection

connect all input/output/battery/wire□check under matters:

- Whether all battery connecting wires join correctly and keep in touch well,
- Input, output, the earth connection has already been connected in the corresponding wiring on the equipment is arranged correctly,
- The voltage of input end, frequency, phase should keep the same with voltage of bypass, frequency, and phase.

7□ Specification□

Model	DS10K	DS15K	DS20K	DS30K	DS40K	DS50K	DS60K	DS80K
VA rating	10KVA	15KVA	20KVA	30KVA	40KVA	50KVA	60KVA	80KVA
Working mode and principle								
True on-line, static bypass(uninterrupted switch), double conversion, input & output complete isolation								
AC input								
Phase	3 phase + N + G							
Voltage	380V ± 25%							
Frequency	50/60Hz ± 5%							
Power factor	0.92 (with input filter)							
Soft start	0 – 100% 5 s (non-shock current)							
Bypass input								
Phase	Single phase							
Voltage	220V ± 20%							
Frequency	50/60Hz ± 5%							
Transfer time	0 ms, Inverter / bypass (overload)							
DC system								
DC voltage	360V (rated voltage)							
	315V (end voltage)							
Current	25A	38A	51A	76A	101A	126A	152A	203A
AC output								
Phase	Single phase							
Voltage	220V ± 1%(stable load); 220V ± 5%(load fluctuation)							
Frequency	50-60Hz ± 0.05% (battery mode)							
Power factor	0.8							
Wave form	Pure sine wave							
Harmonic distortion	<3%(linear load); <5%(non-linear load)							
Dynamic	Dynamic load voltage instantaneous change(0-100%) ± 5%							
Time	Instantaneous recover time <10 ms							
Overload	125% for 1 min; 150% for 1 s							
Cooling	Force ventilation (temperature control mode)							
System								
Efficiency	91%	91%	92%	92%	93%	93%	93%	95%
Communication	RS232 or SNMP							
Temperature	0-40℃ (working)							
Humidity	30-90%							
Working height	< 1000m (1% power reduce per 100 m height rising, Max. 4000m)							
Noise(db)	48-60		53-65		55-65			
Dimension(mm)	430×683×910		430×800×1050		750×720×1450		750×860×1600	

8. Alarming:

8.1 Alarming 1 □ Bypass voltage failure or bypass fuse SCR failure.

It will alarm under these conditions:

1. Bypass input voltage is wrong.
2. Bypass input switch cut off.
3. Bypass SCR fuse cut off or burned because of output short circuit or fuse cut off.

8.2 Alarming 2 □ Main input power failure or rectifier input switch cut off.

It will alarm under these conditions:

1. Input voltage is not in the range □ 184 □ 287 □ V_{AC}.
2. Input frequency is not in the range □ 47.5 □ 54.5 □ Hz.
3. Rectifier input switch cut off.
4. Because UPS is abnormal and cause one phase of three phase rectifier can not work normally, please find out the failure thought consult contents.

8.3 Alarming 3 □ Battery low voltage

It will alarm under these conditions □

1. Battery voltage is too low.
2. The time battery running is shorter than setting time.

8.4 Alarming 4 □ Battery discharge

When battery discharge, it will alarm at once, after 2 minutes, alarm will stop.

Once battery discharge is up to battery final voltage, alarm again.

8.5 Alarming 5 □ Output overload.

When load power is bigger than rated output voltage, namely, more than 100 % □ if

load current is over big, UPS will alarm. When UPS alarm, it needs to reduce load capacity. Or UPS will turn to bypass, we get the time depend on over load value's inverse ratio.

8.6 Alarming 6 □ Temporality bypass working

It indicates bypass supply power; UPS will turn to normally run statue (inverter supply power). There are some conditions under this temporality statue, for example, overload, after bypass supply power, UPS is waiting for power supplied by inverter.

8.7 Alarming 7 □ Bypass output overload

If overload time is too long, for example, overload 125%, inverter can supply power 1min. then turn to bypass. UPS will renew normal running statue.

8.8 Alarming 8 □ High temperature or fan failure

When control system of UPS, inverter power module or rectifier power module is over temperature because of high temperature or fan failure, UPS turn to bypass.

9 □ UPS start up process □

It must be operated to obey these sequence, thought there is battery switch in UPS.

Start up UPS □

9.1. Open input rectifier switch □ Up □.

9.2. Open bypass switch □ UP □

9.3. After battery low voltage indicator crust out, then open battery switch. When UPS is no any alarm statue indicator, bypass will turn to inverter statue.

Notice □ it will display alarming information about the wrong phase sequence if rectifier switch is not cut off, at this time, please press F1 and silence, carry out UPS start up process.

10□UPS maintenance shut down process

10.1.open maintenance switch□up□

10.2.close battery switch□down□

10.3.close rectifier switch□up□

10.4.close bypass switch□down□

10.5.close UPS output switch□down□

11. Emergency shut down process□

When it happens to fire, electric shock, electric arc or other dangerous. user can read this process and operate, but it maybe cause the dangerous that no AC output.

——Make all switches cut off

12□Front panel introduction□

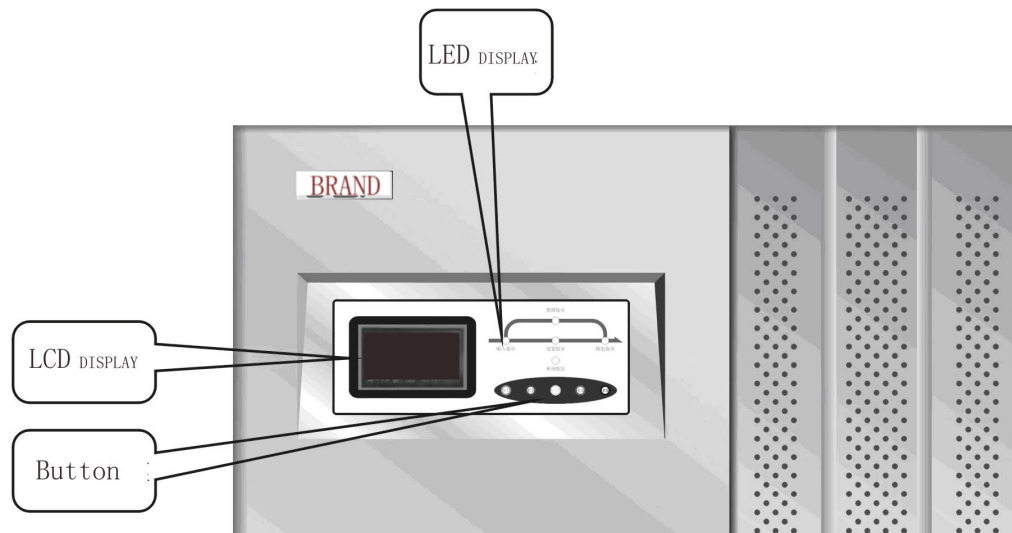

12.1 key introduction:

F1: Functional grouping /silencing

F2: start up

F3: testing

F4: setting

F5: change screen

F1+F2 shut down.

12.2 Press key operation:

system setting □ Notice □ please do not change the original setting, or the wrong system setting will cause abnormal working □, after UPS work normally, please press F5 and look at all parameter and working statue, the display is as following:

Display company information



Tble2-2-1

UPS working statue information □



Table 2-2-2

UPS input information

UPS AC input:	
A Phase voltage: 230V	frequency: 50.0Hz
B Phase voltage: 230V	frequency: 50.0Hz
C phase voltage: 230V	frequency: 50.0Hz

Table 2-2-3

UPS output information:

UPS AC output: voltage: 230V frequency: 50.0Hz current: 000A
--

Table 2-2-4

UPS 3 phase output current and temperature □

Environment temperature :00□ A temperature:00□ B phase current:000A

Table 2-2-5

Battery and UPS parameter□

Battery voltage:000V	bypass times:000
Charge current:00.0A	discharge times:000
Battery quantity:00PCS	discharge time :00:00H
Battery capacity :000AH	UPS capacity:000KVA

Notice: when user does not press any key during a long time, UPS will renew the table 2-2-1 screen and close the LCD back light.